

易格斯农业机械解决方案

# agriculture

igus® solutions for agricultural engineering

plastics for longer life® ...igus

# technology

[igus.com.cn/agriculture](http://igus.com.cn/agriculture) ... [igus.eu/agriculture](http://igus.eu/agriculture)

使用易格斯革新产品，精进技术，降低成本

# cost down ... life up

Improve technology and reduce costs with innovative machine elements from igus®



**高耐磨性，耐污垢，坚固且免维护：适用于农业机械的免润滑工程塑料轴承**

对于农业装备中的轴承产品而言，尽量避免添加润滑油脂，并能提供较长的工作寿命是非常重要的。

在许多应用中，免润滑工程塑料滑动轴承可以取代金属轴套或者滚动轴承。而我们也借此向您提供更具有性价比优势的技术方案。

易格斯工程塑料轴承的优势:

- 自润滑 耐腐蚀
- 高机械稳定性 吸震抗冲击
- 耐尘，耐污垢
- 更好的抗偏载能力，以及优异的抗弯曲性能
- 可根据客户要求定制特殊尺寸产品，
- 对于小批量的需求可以提供 iglidur® 棒材加工件

超过30种在线工具为您**降低成本**。易格斯产品**24到48小时交货**！登陆易格斯农业机械行业网站

Highly wear resistant, dirt-repellant, robust and maintenance-free: lubricant-free polymer plain bearings for agricultural machines

Avoidance of lubricants and long service life are important particularly in agricultural engineering. In many applications, metallic bushings or recirculating ball bearing guides can be replaced by lubricant-free polymer plain bearings. We would like to show you how to improve your technology and save costs at the same time.

The advantages of igus® polymer plain bearings are:

- Self-lubricating
- Corrosion-resistant
- High mechanical stability
- Vibration dampening
- Insensitive to dust and dirt
- Balance of inclinations and bendings
- Special dimensions according to drawing even for small quantities

Around 30 Online-Tools help you to **reduce process cost**. igus® delivers **from stock in 24-48 hours!** Visit our industrial sector website [www.igus.eu/agriculture](http://www.igus.eu/agriculture). I 'm looking forward to talk with you!

期待着与您交流! Yours

季江  
易格斯 iglidur® 滑动轴承产品经理  
Industry Manager, Agricultural technology  
[jjj@igus.com.cn](mailto:jjj@igus.com.cn)



## igus® 样本

igus® catalog product range  
了解更多产品信息，在线申请  
免费样本

[www.igus.com.cn/catalog](http://www.igus.com.cn/catalog)

Excerpt of catalog on next pages,  
order igus® catalogs online [www.igus.eu/catalog](http://www.igus.eu/catalog)



## 服务时间 Ordering times

周一到周六，8:00 - 20:00 From  
Monday to Friday 7:00 am - 8:00 pm  
Saturday 8:00 am - 12:00 pm



## 服务热线 Hotline

电话 Phone 021 5130 3100  
传真 Tex 021 5130 3200



## 在线商铺

访问 [www.igus.com.cn](http://www.igus.com.cn)，可  
以查看多有产品，并且在线下  
单。See [www.igus.eu](http://www.igus.eu). There  
you can find our whole product  
range. Order around the clock.



## 还有其它问题?

You have questions?  
如果您还有其他问题，请访  
问：[www.igus.com.cn](http://www.igus.com.cn) For  
questions and more information  
call us or use our onlinetools on  
[www.igus.eu](http://www.igus.eu).



## 易格斯免润滑产品

Lubrication-free products from igus®



1



**摩擦系数低, 耐磨损, 免润滑:**

**igidur® 工程塑料滑动轴承**

Low coefficient of friction, wear-resistant and lubrication-free: iglidur® polymer bearings

2



**高化学抗性:**

**igubal® 关节轴承及 U 型夹**

Resistant to chemicals:  
igubal® clevis joints and rod ends

3



**可靠运行抗污垢:**

**拖链系统与高柔性电缆**

Resistant to dirt and reliable:  
e-chainsystems® and chainflex® cables

4



**100%免润滑: DryLin® 直线导向系统**

100% lubrication-free: DryLin® linear guides

# ... 清洁 ...

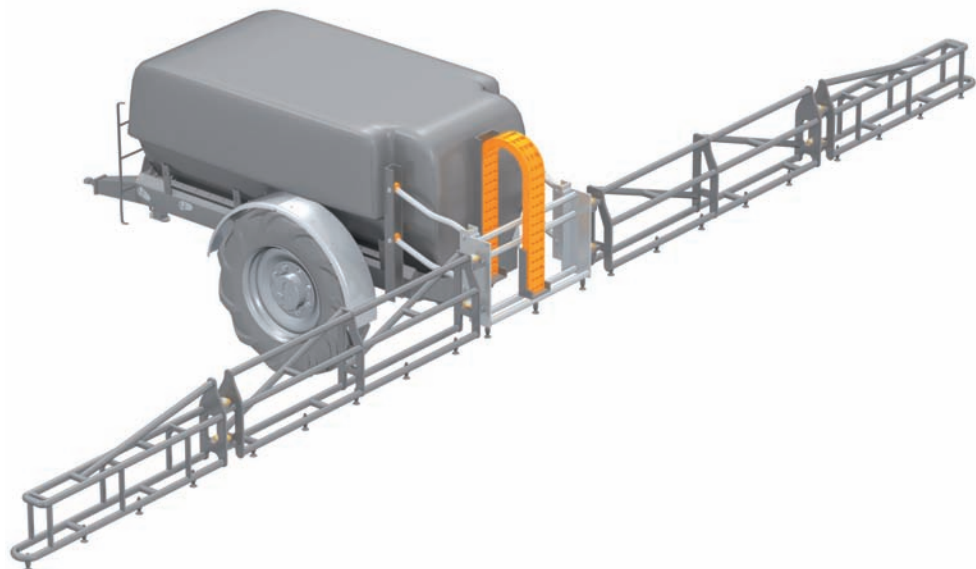

驾驶室  
Cabin



# 免润滑 ...

气弹簧  
Cylinder

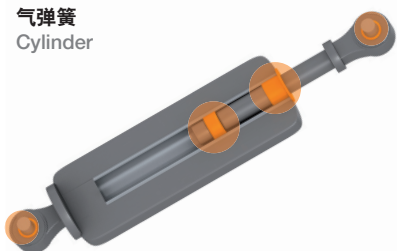

## iglidur® P 工程塑料轴承

- 应用于高表面压力
- 抗冲击

## iglidur® P polymer bearings

- For high surface pressure
- Resistant to shocks

用于承载支架  
Set bearings

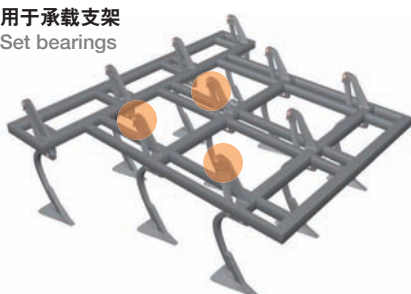

## iglidur® G 工程塑料轴承

- 高静态载荷
- 自润滑，耐腐蚀

## iglidur® G polymer bearings

- High static and impact loads
- Self-lubricating and corrosion-resistant

播种开沟器  
Sowing coultter



动臂结构  
front loader

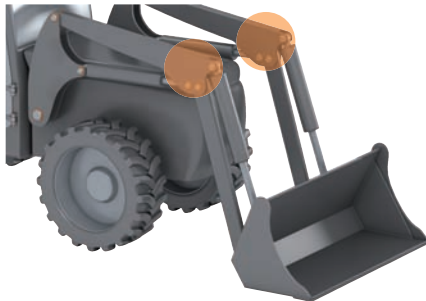

## iglidur® G 工程塑料轴承

- 良好吸振性表现
- 具有介质抗性
- 长时间工作间隔仍能可靠工作

## iglidur® G polymer bearings

- Vibration dampening
- Resistant to media
- Reliably even after long stoppage



## iglidur® Q2 工程塑料轴承

- 适用于高载下的摆动运动
- 抗震动和边缘载荷
- 干运行时免维护

## iglidur® Q2 polymer bearings

- For high-load pivoting applications
- Insensitive to shock and edge loads
- Maintenance-free dry-running

# ... 自润滑无油方案 ...

## 轮轴

Axle bearings

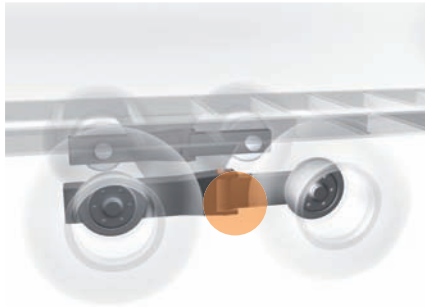

### iglidur® Q 工程塑料轴承

- 高强度，高化学抗性
- 性能稳定，即使长时间不运行后仍可稳定工作

### iglidur® Q polymer bearings

- Extremely robust and resistant to manure
- Reliably even after long stoppage

## 底盘悬挂机构

Chassis bearing / suspension

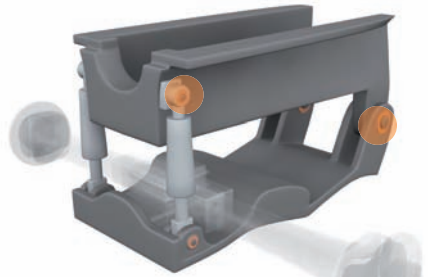

### iglidur® Z 工程塑料轴承

- 适用于高载荷
- 良好吸振性表现
- 在高载下不易错位脱落或抱死
- 极高的耐油性

### iglidur® Z polymer bearings

- For high loads, vibration dampening
- Insensitive to misalignment and hitches
- Resistant to oils and fuel oils

## 提升机构

hydraulic lift

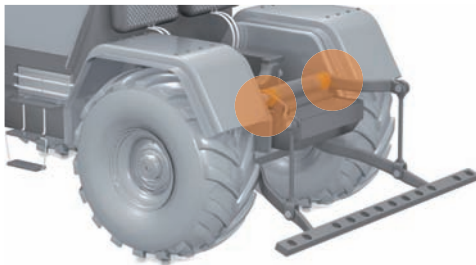

### iglidur® G 工程塑料轴承

- 良好吸振性表现
- 具有介质抗性
- 长时间工作间隔仍能可靠工作

### iglidur® G polymer bearings

- Vibration dampening
- Resistant to media
- Reliably even after long stoppage

## 转向系统和踏板机构

Steering and pedals



### iglidur® J 工程塑料轴承

- 低摩擦系数
- 吸震性良好

### iglidur® J polymer bearings

- Low coefficient of friction
- Vibration dampening

# 应用案例 ...

门铰链机构  
Tractor doors



**iglidur® G 工程塑料轴承**

- 吸震性，可承受边缘载荷
  - 适用于电泳工艺
- iglidur® G polymer bearings
- Vibration dampening and insensitive to edge pressure
  - Suitable for e-coating

牛奶填充  
Milking arm



**iglidur® J 工程塑料轴承**

- 在油污环境中免维护
  - 低摩擦系数
- iglidur® J polymer bearings
- Maintenance-free in extreme dirty areas
  - Low coefficient of friction

拖车  
Trailers

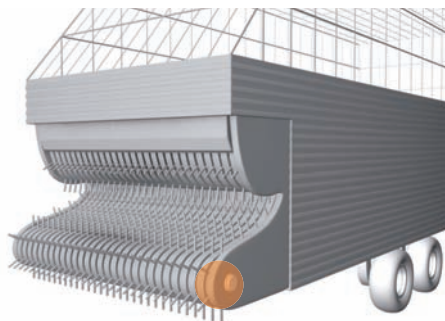

**iglidur® Q 工程塑料轴承**

- 比金属轴承使用寿命更长
  - 适用于软轴
- iglidur® Q polymer bearings
- Longer service life than metal bearings
  - Use of soft shafts

干草吊具  
Hay spreader

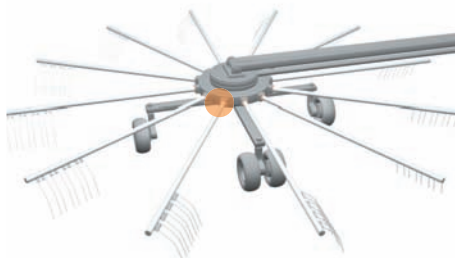

**iglidur® G 工程塑料轴承**

- 高耐磨性，紧凑，防震
  - 适用于软轴
- iglidur® G polymer bearings
- High wear, impact and shockproof
  - Use of soft shafts

# ... 自润滑无油方案 ...

旋转式水泵  
Rotary pump



**igidur® UW 工程塑料轴承**

- 水下工作时磨损极低
  - 经济型解决方案
- igidur® UW polymer bearings
- Low wear in under water applications
  - Cost-effective solution

撒肥机  
Manure distributor



**igubal® U 型夹**

- 耐腐蚀性肥料
  - 高化学抗性
  - 耐腐蚀
- igubal® clevis joints
- Resistant to aggressive fertilizers
  - Chemical-resistant
  - Corrosion-resistant

圈栏技术  
Animal technology



**igubal® 角支轴承**

- 耐灰尘与污垢
  - 自润滑，耐腐蚀
- igubal® pressfit spherical bearings
- Resistant to dirt and dust
  - Self-lubricating and corrosion-resistant

收割机-脱粒机  
Harvester-thresher



**igidur® J 工程塑料轴承**

- 耐磨损
  - 在摆动运动中具有优异的性能
- igidur® J polymer bearings
- Good wear-resistant
  - Highest rating in pivoting applications



# 应用案例 ...



免维护 iglidur® 工程塑料轴承用于树木移植机械上。

Maintenance-free iglidur® G plain bearings for tree transplanter machines



免润滑的 iglidur® 工程塑料轴承用于在恶劣环境中工作的梭型装置。Lubrication-free iglidur® bearings in adverse conditions at shuttle steering axes.



高耐磨性和免维护是选择 iglidur® 工程塑料轴承的主要因素。High wear resistance and low maintenance are the main reasons for the use of iglidur® bearings.

# ... 100 % 免润滑 ...

## iglidur® 是什么？它能做什么？

What is iglidur® and what can it do?

### iglidur® 是什么？

iglidur® 系列工程塑料是由基体材料、增强纤维和固体润滑脂混合而成的高性能聚合物，其性能经过了成千上万余次的测试和实验验证。这种聚合物不是采用简单的表面涂层工艺来实现性能，而是利用均一稳定的分子结构获得更优异的性能。这就意味着，采用此聚合物制成的轴承在高载荷下不会出现表面涂层的脱落现象，从而可以获得比传统的“金属基体加表面涂层”的复合套产品更好的表现，是一种更具性价比的选择。

### What is iglidur®?

iglidur® polymers are enhanced by precisely matched reinforced and solid lubricant additives, tested thousands of times and proven over millions of cycles. The individual components are not simply applied by coating but are homogeneously blended. This means that there is no anti-friction film which can be forced apart under pressure, as is the case of traditional solutions incorporating “hard shell – soft coating” .

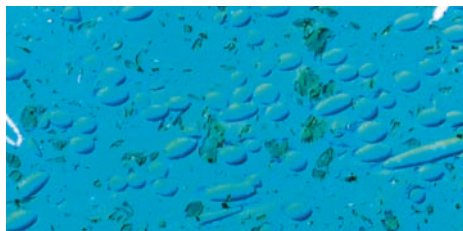
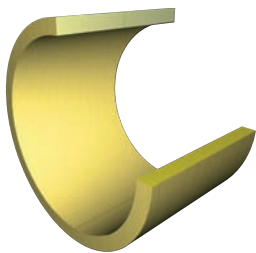

### iglidur® 工程塑料轴承用于农业机械的优势：

- 自润滑
- 耐腐蚀
- 优异的机械性能
- 良好的吸震性
- 耐灰尘和污垢
- 更好的抗偏载能力，以及优异的抗弯曲性能
- 即使有少量的特殊尺寸需求，也可定制

### Advantages of iglidur® polymer plain bearings for agricultural technology

- Self-lubricating
- Corrosion-resistant
- High mechanical stability
- Vibration dampening
- Insensitive to dust and dirt
- Balance of inclinations and bendings
- Special dimensions according to drawing even for small quantities



iglidur® 聚合物：由基料加入加强纤维和固体润滑脂混合而成。（放大200倍后，经染色）

iglidur® Compounds: Basic polymers with fibres and solid lubricants, magnified 200 times, dyed.

# 耐用性测试 ...

## 重载测试

### Heavy-duty testing

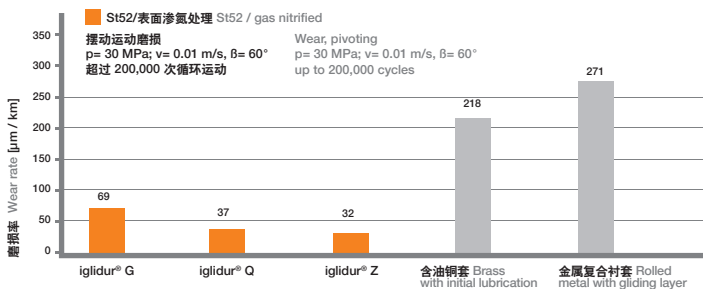

#### 结论:

- ▶ 所有测试的 iglidur® 材料明显表现出低于金属滑动轴承的磨损
- ▶ 配合金属滑动轴承的轴具有明显的磨损, 因此不适合继续使用

#### Conclusion:

- ▶ all tested iglidur® materials exhibit significantly lower wear than metal plain bearings
- ▶ the shafts of the metal plain bearings exhibit significant wear and are therefore unsuited for further use



#### 左图:

左方运动示意图对应上方所描述的测试方案

#### For illustration:

The iglus® pivot test shown left approximately corresponds to this scenario

更多测试结果显示下方的轴/轴表面是可用的并且您可以在任何时间向易格斯询问购买。

- ▶ St52 / 无表面处理
- ▶ C45 / 无表面处理
- ▶ 活塞杆 / 表面硬化处理
- ▶ St52 / 盐浴氮碳共渗
- ▶ C45 / 镀锌

上方轴不包括您的应用吗? 在实际工况条件下易格斯将测试您的具体应用。

More test results with the following shafts / surfaces are available and can be requested at any time.

- ▶ St52 / un-coated
- ▶ C45 / un-coated
- ▶ Piston rods / hard-chromed
- ▶ St52 / saltbath nitrocarburised
- ▶ C45 / galvanised

Is your shaft not included in these? We will gladly test your specific application as well.

# ... 可计算 ...

## 可精确计算的材料性能

### Precisely calculable material properties

iglidur® 滑动轴承是由塑料轴套经过反复测试和计算后形成的轴承产品。易格斯的数据库可能是世界上最庞大的聚合物滑动轴承数据库，可以帮助您准确找到适合您工况的材料。

iglidur® plain bearings mean a step up from the plastic bush to a tested and calculable bearing element. Probably the world's largest database for polymer plain bearings can help you to select the optimum material for your application.

## 最耐磨的易格斯材料

### The iglidur® most wear-resistant material

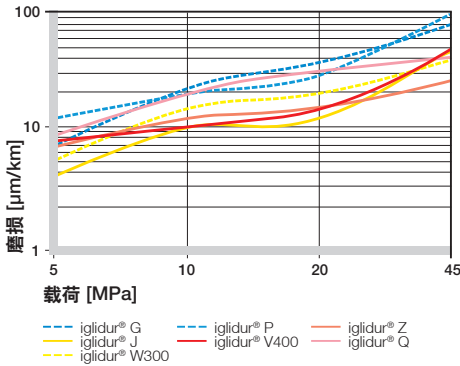

## 可以用于相对粗糙的轴

### Shafts may also be rougher

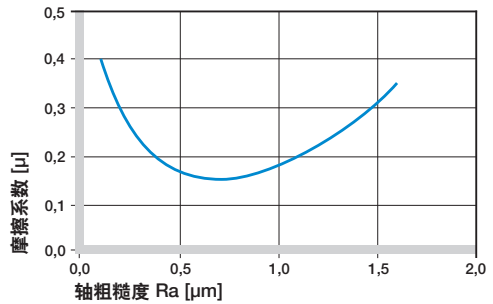

不同的轴表面光洁度下的摩擦系数 (Cf53钢轴)  
Coefficient of friction as function of the shaft surface (shaft Cf53)

在中高载荷下的 iglidur® 滑动轴承的磨损量 wear of iglidur® bearings at medium and high loads

太光滑的轴会造成爬行现象和噪音 Shafts which are too smooth are frequently unfavourable and may lead to stick-slip phenomena and noise

## 可靠的数据库：经过成千上万次测试

### Reliable database: Thousands of test results

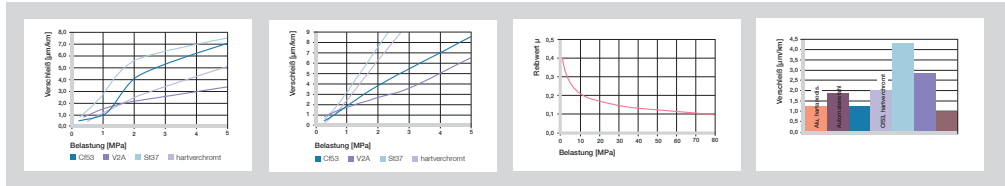

每年超过 5000 次测试实验形成的材料数据体系。

Results of over 15,000 tests per year are incorporated in the iglidur® database.

# 使用寿命 ...

## 在线工具与寿命计算器

Online tools and lifetime calculation



使用寿命计算器  
“Calculate”

### 使用寿命计算器

简单快速地输入应用程序的参数，就能得到一个精确的使用寿命计算结果，并能免费下载3D-CAD文件数据。

### Service life calculation

Simple and quick input of your application parameters, allows a precise calculation of the service life. Also download and save 3D CAD data free of charge.



进入寿命计算器界面输入 iglidur 滑动轴承工作参数计算使用寿命。

- 41 种 iglidur 材料选择
- 合适的 iglidur 材料可以与每个项目的应用相对应
- 可得出匹配轴的价格和交货时间
- 额外的信息，如三维 CAD 数据，技术资料，在线目录等等。

▶ [www.igus.com.cn/igidur-Expert](http://www.igus.com.cn/igidur-Expert)

Entering the application parameters gives you the expected service life for iglidur® plain bearings.

- Choice of 41 iglidur® materials
- Suitable iglidur® materials can be updated with each entry
- The matching shaft is indicated with price and delivery time
- Additional info, such as 3D-CAD data, technical material data, on-line catalog, etc

▶ [www.igus.eu/igidur-Expert](http://www.igus.eu/igidur-Expert)



# ... 100 % 免润滑 ...

## 适用于农业机械的 iglidur® 产品

### igidur® materials for agricultural technology

由 40 种 iglidur® 材料制成的超过 7,000 种直径在 2 毫米至 150 毫米的标准尺寸现货供应。特殊尺寸产品能够短时间交货。

我们为您推荐特别适用于农业机械的材料。

There are more than 40 different iglidur® materials, over 7,000 standard sizes from Ø 2-150 mm are available from stock.

Short delivery times for special sizes.

Especially for agricultural technology we want to show you four exclusive materials.



#### igidur® G 通用型

igidur® G 材料有能满足几乎各种要求，因此它是应用最广泛的轴承材料。适用于中高载荷，中等表面压力和适中的温度。适用于电镀。适用于电泳。

► [www.igus.com.cn/cn/g](http://www.igus.com.cn/cn/g)

#### igidur® G – The Allrounder

The widest range of differing requirements are fulfilled by iglidur® G bearings. That 's why this material is rightly termed universal. Recommended are applications with medium to high loads, medium surface speeds and moderate temperatures. Suitable for e-coating.

► [www.igus.eu/eu/g](http://www.igus.eu/eu/g)



#### igidur® J –

##### 快慢速运动专家

适用于持续运动，软轴也适用。在中低载荷下表现出最佳的耐磨性。即使在潮湿的环境中，也能保持稳定。

► [www.igus.com.cn/cn/j](http://www.igus.com.cn/cn/j)

#### igidur® J –

##### Fast and slow motion specialist

Versatile in continuous operation, for soft shafts too. The perfect combination of wear-resistant bearings at low to medium loads and best coefficients of friction. Extreme dimension stability even in moist applications.

► [www.igus.eu/eu/j](http://www.igus.eu/eu/j)



#### igidur® Z

极高的抗压强度和高弹性使 iglidur® Z 轴承在软轴和高边缘载荷的应用中游刃有余，同时该材料的工作温度可达 +250 ° C。

► [www.igus.com.cn/cn/z](http://www.igus.com.cn/cn/z)

#### igidur® Z

Extremely high compressive strength coupled with high elasticity enables iglidur® Z bearings to attain their prominent features in association with soft shafts, edge loads and impacts. The bearings are at the same time suitable for temperatures up to +250 ° C.

► [www.igus.eu/eu/z](http://www.igus.eu/eu/z)



#### igidur® Q2

碰到 iglidur® 常规材料无法解决的极端载荷，igidur® Q2 可以胜任。专为重载的极端工况设计。

► [www.igus.com.cn/cn/q2](http://www.igus.com.cn/cn/q2)

#### igidur® Q2

Where previous iglidur® bearing solutions in the extreme load range finish, the iglidur® Q2 continues. Made for heavy-duty pivoting applications under extreme conditions.

► [www.igus.eu/eu/q2](http://www.igus.eu/eu/q2)



交货期：24-48 小时  
Shipping after: 24 – 48h



[www.igidur.de](http://www.igidur.de)  
[www.igidur.eu](http://www.igidur.eu)

# ... 100 % 免润滑 ...

## 更多适用于农业机械的易格斯产品

### More igus® products for agricultural technology

#### igubal® 关节轴承

igubal® 关节轴承可以在任何工况中使用。应用环境温度在  $-30^{\circ}\text{C}$  到  $+30^{\circ}\text{C}$ ，并耐灰尘和污垢。

► [www.igus.com.cn/cn/kbrm](http://www.igus.com.cn/cn/kbrm)

#### igubal® 双连杆轴承

igubal® 双连杆轴承满足多规格的客户化组合，如与杆端关节轴承和绕接头的组合就使得很多的应用成为可能；组件均有重量轻，耐腐蚀，耐化学介质，性价比高和优异的减震性能。

► [www.igus.com.cn/cn/wdgm](http://www.igus.com.cn/cn/wdgm)

#### iglidur® 棒料产品

iglidur® 可自由创造产品，现在可以作为一种圆形的棒料，甚至是机械加工的部件，用于测试，原型件生产或小批量需求。iglidur® 棒料为圆形材料，从库存到机械加工的特殊部件或特殊尺寸部件只需3至5天。

快速、经济、可计算使用寿命就选择机械加工滑动轴承。

► [www.igus.com.cn/halbzeuge](http://www.igus.com.cn/halbzeuge)

#### DryLin® W 直线导向系统

DryLin® W 直线导向系统是一个经济实惠的预装配直线导向系统。导轨经阳极氧化处理，提供了最佳的耐磨性和良好的摩擦系数。免润滑，耐污垢。

► [www.igus.com.cn/cn/DryLinW](http://www.igus.com.cn/cn/DryLinW)

#### igubal® Rod Ends

igubal® rod end bearings can also be used without any problems in a tough environment. The application temperatures range from  $-30$  to  $+80^{\circ}\text{C}$ . Noteworthy is the insensitivity to dirt and dust.

► [www.igus.eu/eu/kbrm](http://www.igus.eu/eu/kbrm)

#### igubal® Clevis Joints

igubal® dual joint bearings are available for custom inside micrometer readings starting at a lot size of 1. A variety of applications are conceivable by combining igubal® rod end bearings or angle joints. The components are lightweight, corrosion-resistant, chemically resistant, cost-effective, and vibration-damping

► [www.igus.eu/eu/wdgm](http://www.igus.eu/eu/wdgm)

#### iglidur® bar stocks

iglidur® for free creativity – available now as round bar stock or even as mechanically machined components – for tests, prototypes or small batches. iglidur® materials as round material from stock or mechanically ready-machined special components and special sizes in 3 to 5 days.

Fast and economical. Calculable service life now also for mechanically machined plain bearings.

► [www.igus.eu/barstocks](http://www.igus.eu/barstocks)

#### DryLin® W Modular Guide Systems

The DryLin® W linear guides constitute a cost-efficient preassembled system. Hard-anodized aluminum is used as rail material and provides for the best friction and wear results. The exclusion of lubrication makes the system extremely insensitive to dirt.

► [www.igus.eu/eu/DryLinW](http://www.igus.eu/eu/DryLinW)



交货期: 24-48 小时  
Shipping after: 24 – 48h

# ... 免维护 ...

## 更多适用于农业机械的 iglidur® 产品

More igus® products for agricultural technology



### DryLin® E 线性直线电机

“E”是指电是对 DryLin® 逻辑设计的延伸并结合驱动技术设计工具。无润滑的线性驱动器确保清洁和耐污操作。直线驱动器和驱动装置可配备一个螺纹驱动或齿形皮带传动。

► [www.igus.com.cn/cn/DryLinE](http://www.igus.com.cn/cn/DryLinE)

### DryLin® E | Linear Axes with Motor

“E” means electrical and is a logical design extension of the DryLin® drive technology design kit. The lubricant-free linear drives ensure clean and also dirt resistant operation. Ready to fit linear actuators and drive units can be equipped with either a lead screw drive or toothed belt.

► [www.igus.eu/eu/DryLinE](http://www.igus.eu/eu/DryLinE)



### 拖链与电缆

即使在最严苛的工况下，也能执行各种运动形式，输送电力，天然气，气体和液体，这一切都非常高的动态强调能力和可靠的使用寿命。

► [www.igus.com.cn/e-chain](http://www.igus.com.cn/e-chain)

### e-chains® - designed to guide and protect

Energy Chains® and Energy Chain Systems® are like the umbilical cords of modern machines. They reduce downtimes and increase the service lives of cables and hoses.

► [www.igus.eu/e-chain](http://www.igus.eu/e-chain)



### chainflex® 高柔性电缆

用于拖链或机器人的高柔性电缆，适用于长使用寿命，高速和高加速度。

► [www.igus.com.cn/chainflex](http://www.igus.com.cn/chainflex)

### chainflex® - flexible cables

Cables in energy chains® or on the robot require special properties to survive many cycles, high speeds and accelerations.

► [www.chainflex.eu](http://www.chainflex.eu)

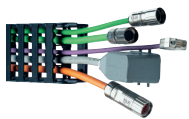

### 装配拖链

使用易格斯装配拖链降低成本，提高现金流。易格斯一次性帮您完成装配拖链与大量附件的安装。

► [www.igus.com.cn/readychain](http://www.igus.com.cn/readychain)

### readychain®

Reduce your costs and increase your cash-flow with the fully harnessed e-chainsystems®. igus® assembles your complete one-time system as well as mass production.

► [www.igus.eu/readychain](http://www.igus.eu/readychain)

### robolink®

轻质，紧凑，自由度高  
关节由高性能工程塑料制成。因不提供执行机构和控制模组，适用于手动机器人和简单的自动化场合。

► [www.igus.com.cn/robolink](http://www.igus.com.cn/robolink)

### robolink®

Lightweight, compact, free.  
Joint made of tribopolymers. Actuators and control module are decoupled from tools - For humanoid robots and easy automation

► [www.igus.eu/robolink](http://www.igus.eu/robolink)





# ... 高科技农业 ...

服务于未来-请联系我们

Ready for the future - please consult us

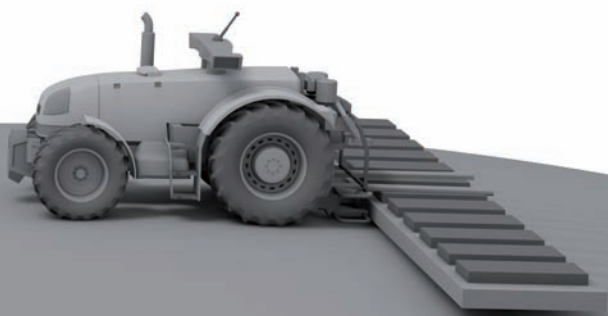

# plastics for longer life® ...

## 生产和研发

### Development and Production



#### 开放式工作空间

Open-plan offices without doors or walls



#### 大批量生产，产品不论大小

Mass production and job production for series both large and small



#### 模具设计

In-house tool design and construction

## 易格斯从何而来？

易格斯的历史开始于1964年10月15日。在开始的20年里，易格斯一直作为精密技术塑料部件的供应商。现在，易格斯已经成为世界著名的拖链制造商和工程塑料轴承专家。

从1985年至今，易格斯的员工人数从40人增加到超过2700人，分布在全球35个国家。

## Where does igus® come from?

It all started on 15 October 1964 in a double garage in Cologne Mülheim, Germany. During the first 20 years, we worked as a supplier of complex, technical plastic parts. Today, igus® is an important manufacturer of e-chainsystems® made of plastic and a specialist in polymer plain bearings .

Between 1985 and today, igus® grew from 31 to over 2,200 co-workers, working in 35 countries.

## 易格斯质量控制

易格斯的质量控制体系的建立基于客户的需求，作为客户的有竞争力且可靠的合作伙伴，并且一直遵循着最高的质量标准，同时，不断开发着创新方案。

## igus® quality assurance

The quality policy of igus® GmbH is based on establishing the needs of our customers, meeting these needs, and always being a competent partner and reliable supplier. igus® has always undertaken to manufacture products with the very highest possible quality standard and, in addition, to constantly develop innovative solutions.



### 庞大的轴承数据库

Great polymer plain bearing database

### 庞大的实验数据和数据处理

igidur® 滑动轴承与普通塑料轴套相比最大的优势是可计算的机械零件。每年超过5,500次的试验，形成全球最大的塑料滑动轴承运动性能的数据库。通过这个数据库，我们将向您提供适用于您工况的最佳性价比的材料。

### Extensive test database

igidur® plain bearings mean the step from a plastic bushing to a tested and, thus, calculable machine element. Over 15,000 tests per year have resulted in the probably world's largest database relating to the tribological properties of polymer plain bearings. This database allows us to select the bearing with the best price-service life ratio for your specific application.

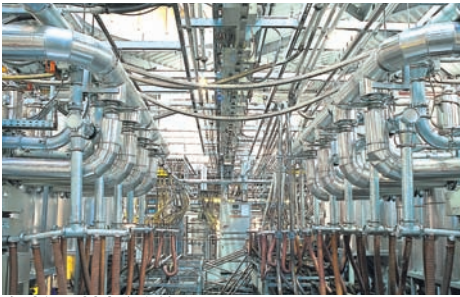

### 自动化原料生产和输送

Automated material preparation and conveying

### 现代、高效的注射工艺

高科技的方案，使提供优惠价成为可能。我们采用经济高效的现代化注射工艺，精确的流程控制系统能保证超过7,000种产品准时地制造。我们拥有200台设备，生产压力最大能达到130吨。服务时间为周一到周六从早上8:00至晚上8:00。无最小订货量，无额外费用。付款后即送货！

### Modern, efficient injection molding

High-tech solutions at a discount price. Our modern injection molding systems allow cost-effective, controlled-process manufacture of over 7,000 standard and numerous special parts, all just in time! Our production runs on 200 machines with a locking pressure of up to 130 tons. Our "7 to 8 + Saturday to 12" service offers you the certainty of being able to respond quickly to changes in demand at short notice.

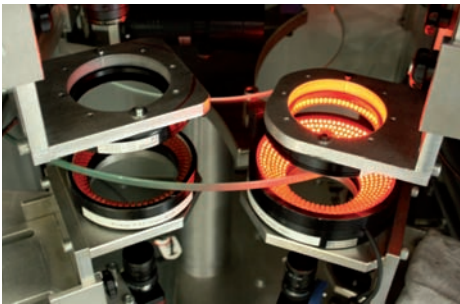

### 产品尺寸的自动化光电检测系统-100%检测控制，

每秒10件 Optical tests on automatic systems -

100% control, up to 10 pieces per second

# 同行业中最大的测试实验室

1.750 m<sup>2</sup> 的测试实验室，每年超过 15,000 项测试，超过20亿次循环  
1,750 m<sup>2</sup> lab, more than 15,000 tests and 2 billion test cycles per year



更好的产品，更实惠-关键之处：易格斯专注于研究与开发。

Better products, but more affordable – a key ingredient: igus® research and development.

## igus® 实验室与实践经验

在降低成本的同时保证最高标准的可靠性：那些投入大量资源到测试和研究的企业，如易格斯，才能满足日益竞争激烈的使用要求。此行业最大的测试实验室每年要进行超过20亿次测试，总投入107个测试基站。

我的生产的机械零部件在出易格斯仓库之前都经过了严格的测试考研。

更多信息：

▶ [www.igus.com.cn/cn/test](http://www.igus.com.cn/cn/test)

## igus® laboratory and practical experience

Reducing costs while guaranteeing the highest possible process reliability: only those who invest considerable resources into testing and research, such as igus®, can successfully address these competing requirements. The largest test lab in the industry conducts more than 2 billion test cycles annually on a total of 107 test stations.

Our mechanical engineering components pass the litmus test presented by production reality, because they have already passed this test before leaving the igus® warehouse.

More information:

▶ [www.igus.eu/eu/test](http://www.igus.eu/eu/test)

# 免润滑 ...

plastics for longer life<sup>®</sup> – 保护我们的环境

plastics for longer life<sup>®</sup> – also for the sake of the environment



## 免润滑，重量轻

易格斯的iglidur<sup>®</sup>工程塑料轴承无需油和油脂用于润滑。得益于工程塑料轴承专家易格斯长久以来对技术的不断创新，为了保护环境，越来越多需润滑的金属轴承可以被免润滑的塑料轴承所替代。就工程塑料轴承的生产来说，其能源利用率非常之高。制造1升铝需要消耗15升原油，制造1升钢需要消耗11升原油，而制造1升塑料只需消耗1.8到2.3升原油。

## 保护环境

易格斯工程塑料轴承无需润滑剂，不会对环境产生污染。轻质轴承减少燃料的消耗，并减少碳排放。

一项研究表面，超过一半的润滑剂渗透到土壤和水域或蒸发到大气中。根据亚琛工业大学一个由化学家、机械工程师和环保专家组成的研究小组的研究，德国每年要向环境排放25万吨润滑剂，相当于能装满8000辆油罐车。

## Lubrication-free and lightweight

The tribo-optimised iglidur<sup>®</sup> plastic plain bearings from igus<sup>®</sup> require neither oil nor grease. Due to continuous advanced developments the bearings specialist igus<sup>®</sup> now supplies alternatives more in line with environmental considerations for more and more applications that work with lubricated metallic plain and rolling bearings. The energy balance for the manufacture of plastics is very positive. Whereas the energy from 15 litres of oil is necessary to produce 1 litre of aluminum, and 1 litre of steel requires 11 litres of oil, the production of 1 litre of plastic only needs an average of 1.8 to 2.3 litres of oil.

## Better for the environment

iglidur<sup>®</sup> bearings are lubricantfree, so that no contaminants escape into the environment. The lightweight bearings will also help to reduce fuel consumption and carbon dioxide output.

A study has found that **no less than half** of all machine lubricants currently used in Germany seeps into soil and waters or evaporates into the atmosphere. According to a research team of chemists, mechanical engineers and environmentalists from the RWTH in Aachen, the estimates for Germany alone consume 250,000 tonnes per year. This corresponds to the amount required to fill 8,000 tankers.

# igus® 服务 ...

组件服务，在线工具，易格斯产品服务... 24 小时在线！

Assembly service, online tools, igus® service... from stock in 24h!



为了准确装配和避免停机所造成的额外费用-可交付于 igus® 拖链系统装配服务

- 产品和服务都来自同一供应商 - 减少物流成本
- igus® 系统保障

► [www.igus.com.cn/montageservice](http://www.igus.com.cn/montageservice)

Get an accurate assembly and avoid machine downtimes and extra costs – with the igus® e-chainsystem® assembly service

- Products and services from one source – less logistical hassle for you
- igus® system guarantee

► [www.igus.eu/assemblyservice](http://www.igus.eu/assemblyservice)



## igus® 样本产品范围

igus® catalog product range

[www.igus.com.cn/catalog](http://www.igus.com.cn/catalog), 可以找到易格斯所有产品，并随时可进行购买

Excerpt of catalog on next pages, order igus® catalogs online [www.igus.eu/catalog](http://www.igus.eu/catalog)



## 在线商铺

访问 [www.igus.de](http://www.igus.de). 能找到您所需的产品。See [www.igus.eu](http://www.igus.eu). There you can find our whole product range. Order around the clock.



## 常备库存. 24 小时发货

Delivery from stock. 24h or on request.

货物将在24小时内从易格斯仓库发出。根据您的要求安排物流。The goods leave igus® within 24 hrs. On request we can deliver via express or special delivery.



## 服务时间 Ordering times

周一到周六 8:00 - 20:00

Monday to Friday 7:00 am - 8:00 pm

Saturday 8:00 am - 12:00 pm



## 服务热线 Hotline

电话 Phone 021 5130 3100

传真 Fax 021 5130 3200



## 其它问题？

You have questions?

任何问题或更多信息都可以登录：[www.igus.de](http://www.igus.de).

For questions and more information call us or use our onlinetools on [www.igus.eu](http://www.igus.eu).



## 免费样品

Free samples

索要您所需要的样件在 [www.igus.com.cn/samples](http://www.igus.com.cn/samples), Order your free sample of any igus® product online at [www.igus.eu/samples](http://www.igus.eu/samples)

## 重要在线工具一览

A selection of important Online-Tools for your industrial sector



**QuickChain.100**  
拖链设计和计算器  
Calculation & layout of e-chains®

- ▶ [www.igus.com.cn/eks-experte](http://www.igus.com.cn/eks-experte)
- ▶ [www.igus.eu/ecs-expert](http://www.igus.eu/ecs-expert)



**QuickChain.13**  
13 m 以下拖链查找器  
product finder up to 13 m

- ▶ [www.igus.com.cn/quickchain13](http://www.igus.com.cn/quickchain13)
- ▶ [www.igus.eu/quickchain13](http://www.igus.eu/quickchain13)



**QuickLife**  
拖链使用寿命计算器  
Service life of e-chains®

- ▶ [www.igus.com.cn/eks-lebensdauer](http://www.igus.com.cn/eks-lebensdauer)
- ▶ [www.igus.eu/ecs-lifetime](http://www.igus.eu/ecs-lifetime)



**QuickFind**  
产品查找器  
Product finder

- ▶ [www.igus.com.cn/eks-finder](http://www.igus.com.cn/eks-finder)
- ▶ [www.igus.eu/ecs-finder](http://www.igus.eu/ecs-finder)



**QuickFill**  
拖链装填专家 e-chain®  
filling expert

- ▶ [www.igus.com.cn/ia-konfigurator](http://www.igus.com.cn/ia-konfigurator)
- ▶ [www.igus.eu/filling-configurator](http://www.igus.eu/filling-configurator)



**QuickCad circular**  
圆周运动拖链配置器  
e-chains® with circular motion

- ▶ [www.igus.com.cn/rbr-konfigurator](http://www.igus.com.cn/rbr-konfigurator)
- ▶ [www.igus.eu/rbr-configurator](http://www.igus.eu/rbr-configurator)



**QuickCad spiral**  
螺旋拖链配置器  
spiral e-chains®

- ▶ [www.igus.com.cn/twisterkonfigurator](http://www.igus.com.cn/twisterkonfigurator)
- ▶ [www.igus.eu/twisterkonfigurator](http://www.igus.eu/twisterkonfigurator)



**QuickCable**  
电缆产品查找器  
Product finder cables

- ▶ [www.igus.com.cn/quickcable](http://www.igus.com.cn/quickcable)
- ▶ [www.igus.eu/quickcable](http://www.igus.eu/quickcable)



**QuickLife**  
使用寿命计算器  
Service life calculation

- ▶ [www.igus.com.cn/cf-lebensdauer](http://www.igus.com.cn/cf-lebensdauer)
- ▶ [www.igus.eu/cf-lifetime](http://www.igus.eu/cf-lifetime)



**QuickPin 2.0**  
电缆接配置器 Connector-  
cable configurator

- ▶ [www.igus.com.cn/quickpin](http://www.igus.com.cn/quickpin)
- ▶ [www.igus.eu/quickpin](http://www.igus.eu/quickpin)



**QuickBearing**  
iglidur® 查找器  
iglidur® product finder

- ▶ [www.igus.com.cn/iglidur-productfinder](http://www.igus.com.cn/iglidur-productfinder)
- ▶ [www.igus.eu/iglidur-productfinder](http://www.igus.eu/iglidur-productfinder)



**QuickBearing.custom**  
棒料查找器  
Product finder for stock bars

- ▶ [www.igus.com.cn/halbzeuge-productfinder](http://www.igus.com.cn/halbzeuge-productfinder)
- ▶ [www.igus.eu/stockbar-productfinder](http://www.igus.eu/stockbar-productfinder)



**QuickLin**  
DryLin® 系统设计  
DryLin® system design

- ▶ [www.igus.com.cn/DryLin-experte](http://www.igus.com.cn/DryLin-experte)
- ▶ [www.igus.eu/DryLin-expert](http://www.igus.eu/DryLin-expert)



**QuickLin**  
驱动产品查找器 product  
finder drive technology

- ▶ [www.igus.com.cn/sht-productfinder](http://www.igus.com.cn/sht-productfinder)
- ▶ [www.igus.eu/sht-productfinder](http://www.igus.eu/sht-productfinder)



**QuickRobolink**  
多轴机器人关机配置器  
Multi-axis- joint configurator

- ▶ [www.igus.com.cn/roboLink-konfigurator](http://www.igus.com.cn/roboLink-konfigurator)
- ▶ [www.igus.eu/roboLink-configurator](http://www.igus.eu/roboLink-configurator)

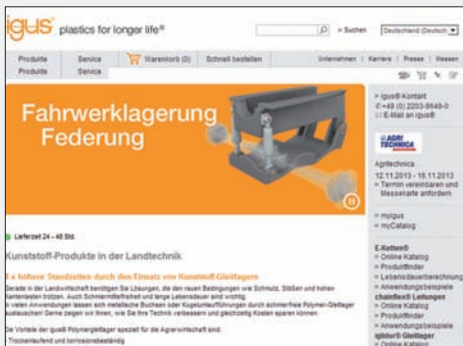

[www.igus.com.cn/agrar](http://www.igus.com.cn/agrar)

更多信息，应用案例、视频和产品细节，请访问我们的网站。

[www.igus.eu/agrar](http://www.igus.eu/agrar)

There you can find information, applications, videos and product details.

# /9001:2008 /16949:2009

易格斯拖链、轴承、电缆及装配符合ISO 9001:2008 及 ISO/TS 16949:2009 标准。igus® is certified in accordance with ISO 9001:2008 and ISO/TS 16949:2009 in the field of energy supply systems, cables and harnessing, as well as plastic bearings.

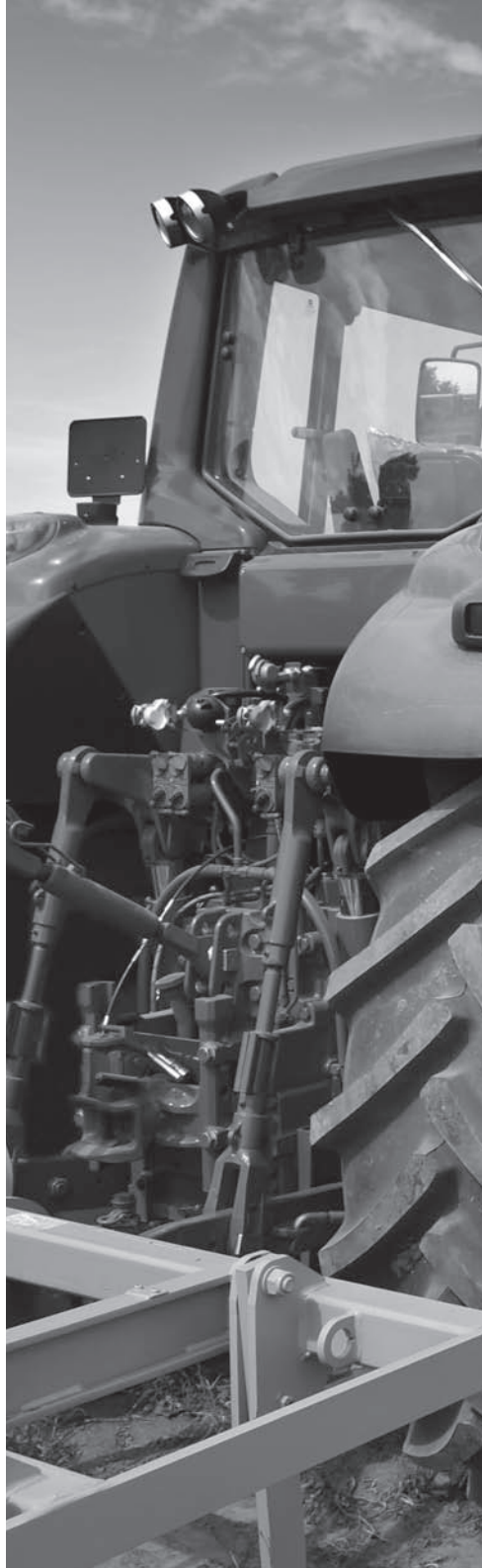

# igus®

易格斯拖链轴承仓储贸易（上海）有限公司  
上海市外高桥自贸区德堡路11号46号厂房

邮编：200131

电话：021-5130 3100

传真：021-5130 3200

免费服务热线：400 720 3100

E-mail: [master@igus.com.cn](mailto:master@igus.com.cn)

<http://www.igus.com.cn>

© 2015 igus® GmbH

易格斯保留最终解释权！

MAT0070706.14 截至 07/2015